

Call Letters	PSTC-14
Date of Issuance	11/70
Revised	08/85
Revised	08/89
Revised	06/00
Revised	10/03
Revised	05/07

Adhesion of Pressure Sensitive Tapes To Fiberboard at 90° Angle and Constant Stress

1. DEFINITION

1.1 Adhesion to fiberboard at 90° angle and constant stress is the time required to remove a unit length of a pressure sensitive tape from a given fiberboard under a controlled constant stress. The user of this method has the option of choosing the paper surface for the test. The test surface shall be the standard linerboard.¹ If another linerboard or paper is used, it should be noted in the test report.

2. SIGNIFICANCE

2.1 This test is designed to show the adhesion of a pressure sensitive tape to fiberboard when the tape is under constant stress. Test data from this test for some types of packaging tapes relate to tape performance on fiberboard box closure.

2.2 Procedure A should be used when comparing tape to an established requirement. The requirement may be established using either the standard linerboard or another linerboard representing a specific fiberboard.

2.3 Procedure B should be used to rank tapes as to their ability to adhere to fiberboard.

3. SPECIMEN

3.1 For test specimen conditioning, selection, and test conditions, see Appendices A & D.

3.2 A roll or rolls of tape for testing must be at least 36 mm (1.5") in width. Test five specimens from each roll of tape.

4. EQUIPMENT

4.1 Double coated pressure sensitive tape 48 mm (2") in width. Tape must exhibit sufficient adhesion to the test panel and to the fiberboard or test specimens for duration of test.

4.2 Panel, any steel piece at least 50 mm x 125 mm x 1.6 mm (2" x 5" x 1/16") having one surface 50 x 125 mm (2" x 5") that does not deviate from a plane by more than 0.05 mm (0.002").

4.3 Stop watch.

4.4 Cutting device for preparing fiberboard and tape specimens.

4.5 Mask, any paper no more than 0.05 mm (0.002") thick formed by a rectangle approximately 125 x 62.5 mm (5" x 2.5") with a rectangular hole exactly 24 ± 0.25 by 31 mm ($1.0" \pm 0.01"$ by 1.25") centered in the piece. The 24 mm (1") hole is to be in the 125 mm (5") direction. See Figures 1 and 2.

4.6 Chipboard piece, approximately 1" x 1" (24 x 24 mm) for reinforcement.

4.7 Single hole paper punch.

4.8 Fiberboard or linerboard one surface against which the test is made.

A Summary of Changes section appears at the end of this test method.

4.8.1 For Procedure A, cut a rectangle exactly 24 ± 0.25 mm ($1.0'' \pm 0.01''$) wide by at least 125 mm (5'') in length from the linerboard representing the fiberboard on which the tape will be used. The long dimension shall lie at a right angle to the machine direction of the linerboard. Reinforce the end of the strip with a chipboard piece adhered with double coated tape. Punch a hole at the center of the reinforcement.

4.8.2 For Procedure B, cut a rectangle, preferably 125 x 48 mm (5'' by 2''), but no less than 48 x 48 mm (2'' by 2''), from the fiberboard on which the tape will be used (or linerboard representing it). The long test dimension shall lie at a right angle to the machine direction of the linerboard.

4.8.3 For either procedure, prepare the linerboard or fiberboard in advance of testing and mark it to show which side to use. When comparing one roll of tape to another or one lot of tape to another, the linerboard or fiberboard should be from a single lot.

4.9 Rubber-covered roller. See Appendix B.

4.10 Test stand to support the panel securely in a horizontal plane during the test period.

4.11 Weight, 200 ± 0.2 g with hook.

4.12 Timing system, for measuring test time in minutes.

4.13 Paper, clean, unprinted, must not have a coating of any kind, for use in adhering fiberboard to panel.

4.14 Razor blade, single edge.

5. PROCEDURE A

5.1 Adhere the double-coated tape to the panel with firm finger pressure and remove the liner.

5.2 Lightly sand the backing of the tape on the roll for approximately 250 mm (10'') with 300 grit sandpaper to remove the easy unwind treatment. Start timing with the stop watch. Immediately unwind 300 to 450 mm (12 to 18'') of tape from a freely rotating roll at a rate of 500 to 750 mm/s (20'' to 30''/s).

5.3 Center this strip, adhesive side up, on the panel, aligning the long edges parallel with the panel long edges. Trim to panel dimensions. Do not allow any object to contact the adhesive.

5.4 Place a mask at the center of the specimen so that the 24 mm (1'') dimension of the hole in the mask lies parallel to the long dimension of the specimen edges (see Figure 1). Rub against the mask to assure that the tape specimen is well adhered to the double coated tape on the panel. Avoid touching the adhesive.

5.5 At 90 ± 5 seconds, position the linerboard strip (end opposite the hole) to span the mask and center it lengthwise on the specimen adhesive. Assure that the correct side of the linerboard is placed against the specimen adhesive. Do not apply any finger pressure to the specimen. Continue timing.

5.6 Roll the linerboard against the specimen lengthwise once each way at a rate of 300 mm/min. (12''/min.), using the rubber-covered roller.

5.7 Immediately set the panel, specimen side down, into the test stand, assuring that it will remain in a horizontal plane throughout the test.

5.8 At $180 \text{ seconds} \pm 5 \text{ seconds}$ (3 minutes from unwinding the tape from the roll), add the 200 g weight so that no shock load is imparted to the linerboard and immediately start the timer. Allow the test to continue until the linerboard has peeled free from the specimen adhesive.

5.9 Void all tests where the tape (test specimen) has pulled away from the panel (either the specimen from the double coated tape or the double coated tape from the panel). When this occurs, repeat the test assuring that the panel, the double-coated tape, and the test specimen are well bonded together.

6. PROCEDURE B

6.1 Adhere double coated tape to panel and remove liner.

6.2 Superimpose the fiberboard on the double-coated tape, exposing the correct side and assuring that the machine direction is at a right angle to the long dimension of the panel. Handle the fiberboard only at edges and corners so that an area at least 36 mm (1.5") square at its center is absolutely free of contamination.

6.3 Place a clean sheet of paper (item 4.13) on top of the fiberboard. Rub against this to assure that the fiberboard is well bonded to the double-coated tape on the panel. Do not rub fiberboard surface with the paper or fingers.

6.4 Start timing with stop watch. Immediately unwind 300 to 450 mm (12 to 18") of tape at a rate of approximately 500 to 750 mm/s (20 to 30"/s).

6.5 From the center of this strip cut specimen 24 ± 0.25 mm (1.0 ± 0.01 ") wide and at least 168 mm (7") in length. Handle this strip by its ends only. Do not allow adhesive to contact any object.

6.6 Lay the specimen, adhesive side up, on the work bench and tape the ends down to hold specimen flat.

6.7 Apply a mask at one end of the specimen so that the 24 mm (1") dimension of the hole lies parallel to the specimen's long edges (see Figure 2).

6.8 Cut away the taped end of the specimen at the mask.

6.9 Apply chipboard square to exposed adhesive at end of specimen. Punch hole for attaching hook of weight.

6.10 At 90 ± 5 seconds position the specimen lengthwise on the fiberboard, adhesive side down, so that the 24 x 24 mm (1" by 1") adhesive area is approximately centered on the fiberboard. Do not apply any finger pressure to specimen. Continue timing.

6.11 Roll specimen lengthwise once in each direction at a rate of 300 mm/min. (12"/min.) using the rubber-covered roller.

6.12 Immediately set the panel, specimen side down, into the test stand assuring that it will remain in a horizontal plane throughout the test.

6.13 At 180 ± 5 seconds (a total of 3 minutes from unwinding the tape from the roll), add the 200 g weight so that no shock load is imparted to the specimen and start timers. Allow test to continue until the specimen has peeled free from the fiberboard (see Figure 3).

6.14 Void all tests where fiberboard has pulled away from the panel (either the fiberboard from the double-coated tape or the double-coated tape from the panel). When this occurs, repeat test assuring that the panel, double-coated tape, and the fiberboard are well bonded together.

7. CALCULATIONS

7.1 To determine the final test result for the roll of tape under consideration, take an average of the individual test results and calculate the standard deviation. Individual test values should be recorded. The average of the individual results and the standard deviation is considered the test result. No single specimen value shall be considered as representative of the roll under test.

8. REPORT

8.1 The report shall include the following:

8.1.1 Identification of tape tested.

8.1.2 Fiberboard identification.

8.1.3 Anomalous behavior during the test, i.e., adhesive transfer or splitting, paper fiber pulled free from fiberboard, delamination of fiberboard.

8.1.4 The mean time value calculated in section 7.

8.1.5 Which procedure was used.

Another method for measuring adhesion of pressure sensitive tape to fiberboard at 90° angle and constant stress is ASTM D 2860.

¹The linerboard accepted as the standard test surface, Standard Reference Material 1810A, is available from the Office of Standard Reference Materials, National Institute of Standards and Technology, Washington, D.C. 20234.

SUMMARY OF CHANGES

- Clarified definition in section 1.1.
- Made consistent metric references of 24 mm and 48 mm for standard 1" and 2" tape rolls.

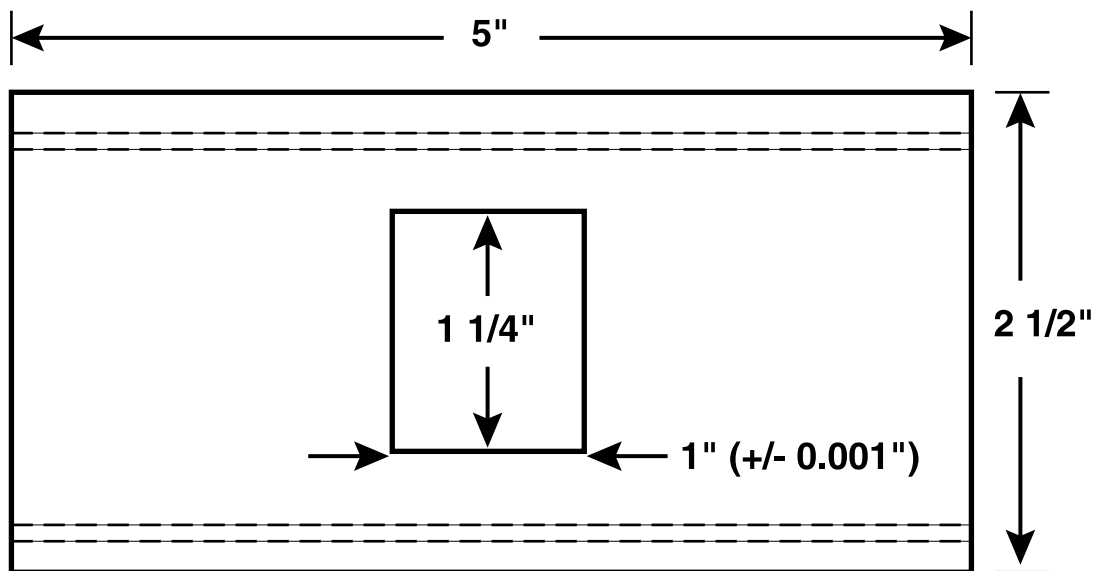

Figure 1. Procedure A test construction.

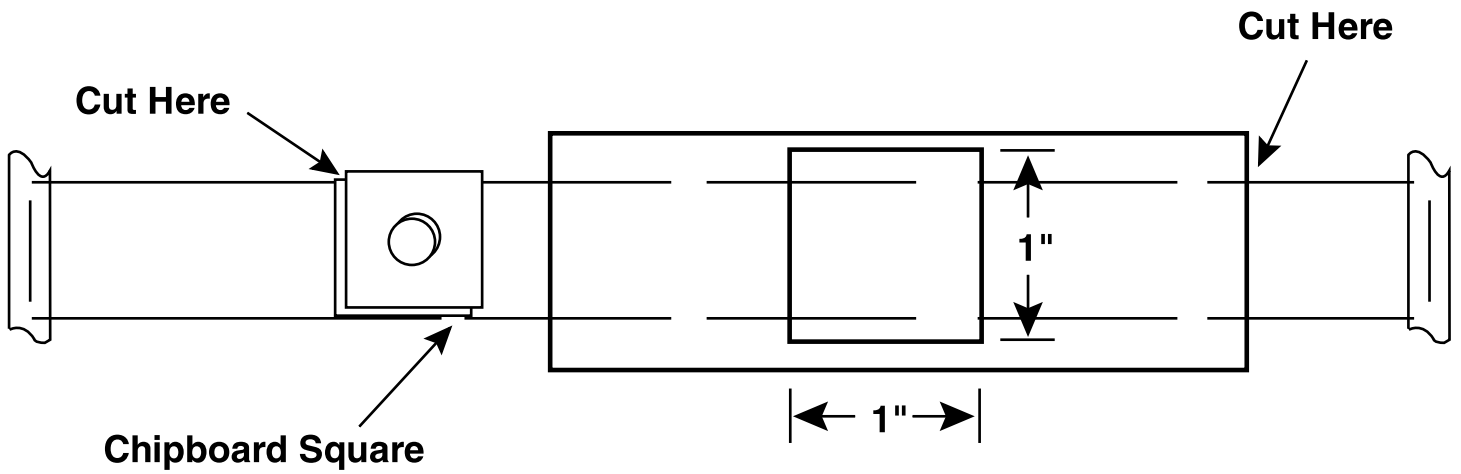

Figure 2. Procedure B test construction.

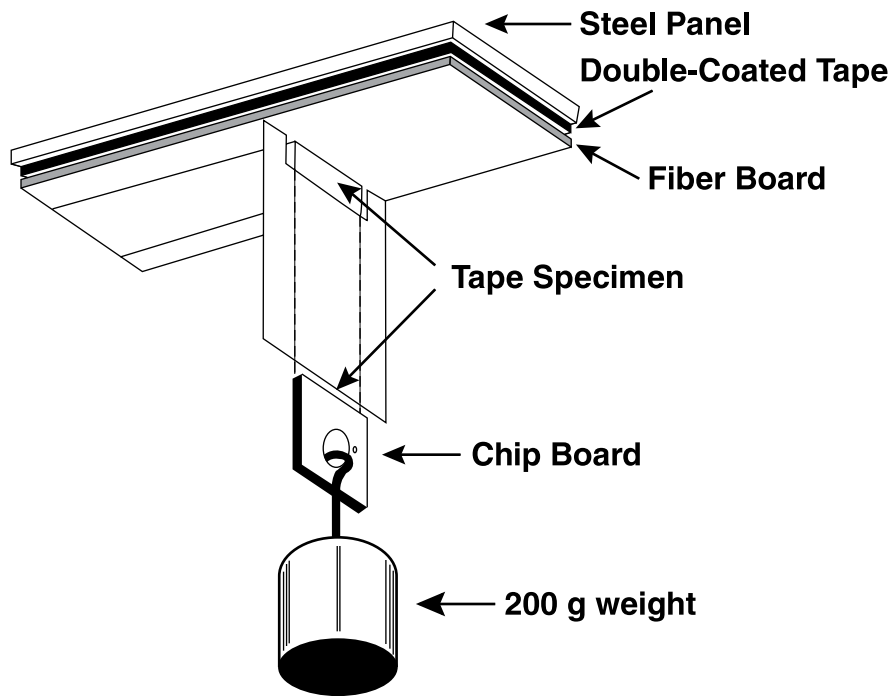

Figure 3. Test construction for adhesion of pressure sensitive tapes to linerboard.

